

Features

- Low Insertion Loss
- High Attenuation
- Compact Size
- SMA Connector Mount

Descriptions

SMA connector mount lumped element bandpass filter developed for VHF band applications.

Electrical Specifications

Parameter	Unit	Specification
Center Frequency (Fc)	MHz	70
Passband Frequency Range	MHz	50 ~ 90
Insertion Loss @ Fc	dB	1.0 max
Return Loss in Passband	dB	17.0 dB min
Rejection bands	dBc	20 min @ 20MHz
		35 min @ 235MHz
Group Delay Variation	ns	10 max
Input Power	Watt	1 CW max
In / Out Impedance	Ohm	50
Operating Temperature Range	°C	0 to +50
Dimension	inch	1.25 X 0.55 X 0.4
RoHS	-	Yes

Mechanical Drawing

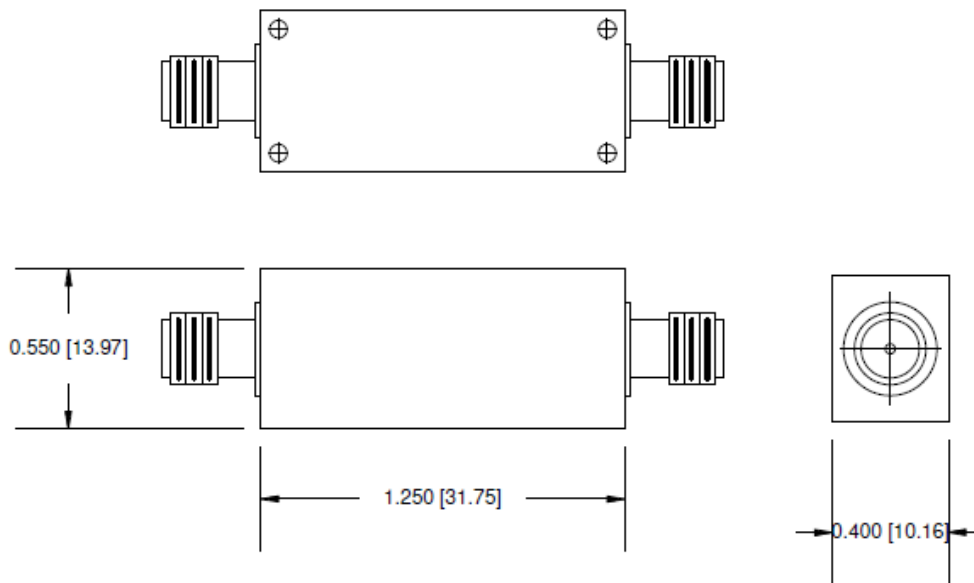

Electrical Response

