

Features

- Low Insertion Loss
- High Attenuation
- Compact Design
- Surface Mount

Descriptions

Surface mount ceramic bandpass filter developed for GPS L1 band applications.

Electrical Specifications

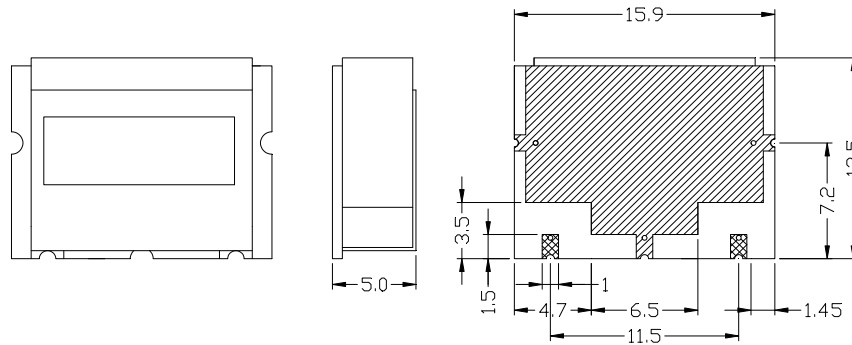

Parameter	Unit	Specification
Center Frequency	MHz	1575.42
Passband Frequency Range	MHz	1564~1586
Insertion Loss at Fc	dB	3.0 max
Ripple in Passband	dB	1.0 max
Return Loss (VSWR) in Passband	dB	1.5:1 max
Attenuation	dB	12 min Fc±35 MHz @ 1540 & 1610 MHz
		40 min Fc±140 MHz @ 1435 & 1715 MHz
In/Out Impedance	Ohm	50
Power Handling	Watt	1 (CW) max
Operating Temperature	°C	-40 ~ +85
Dimensions (max)	mm	15.9 x 12.5 x 5.0 (L x W x H)
RoHS	-	Yes

Mechanical Drawing



Tolerance unless otherwise specified : ±0.2

Dimension unit : mm

 : GND
 : Port

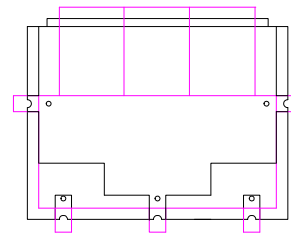

Electrical Response

