

## Features

- Low Insertion Loss
- High Attenuation
- Compact Size
- Surface Mount

## Descriptions

Surface mount discrete resonator ceramic bandpass filter developed for L band applications.

## Electrical Specifications

Parameter	Unit	Specification
Center Frequency (Fc)	MHz	1190
Passband Frequency Range	MHz	1170-1210
Insertion Loss @ Fc	dB	3.0 max
Passband Flatness	dB	1.0 max
Return Loss in Passband	dB	14.0 min
Attenuation	dB	70 min @ 960 MHz
		70 min @ 1450-2000 MHz
		50 min @ 2000-6000 MHz
Operating Input Power	Watts	3.0 CW max
IN/OUT Impedance	Ohm	50
Operating Temperature	°C	-30 ~ +85
Dimensions	mm	31.75 x 12.7 x 7.1 (L x W x H)
RoHS	-	Yes

## Mechanical Drawing

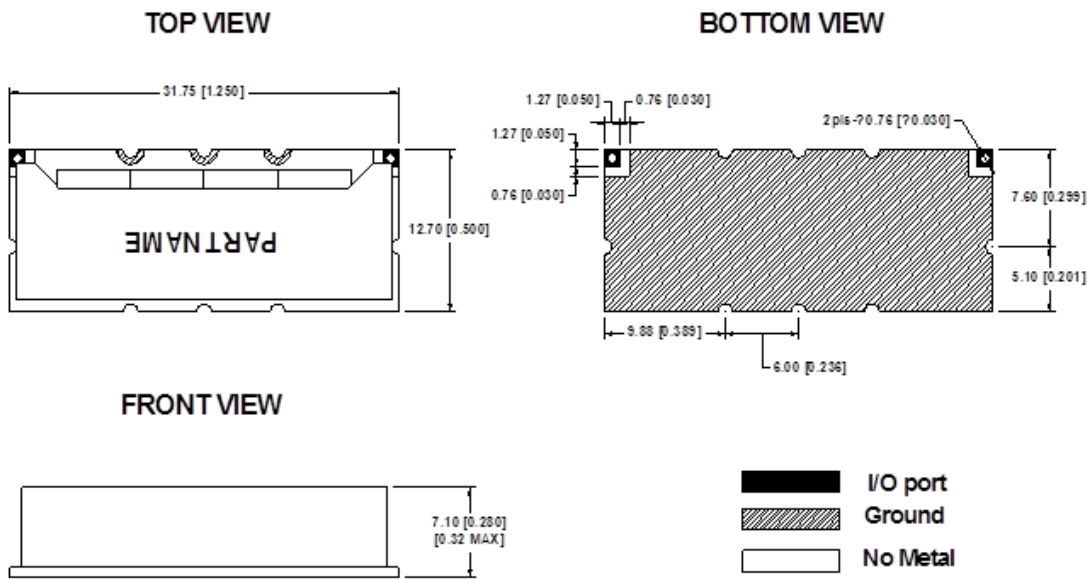

## Electrical Response

